

**SAVE THESE INSTRUCTIONS FOR FUTURE USE**

- ⚠ **WARNING: Important! Read and understand these instructions before installing or using the Anti-Fold Bar. If you do not understand any part of these warnings, cautions or instructions, contact a healthcare professional for direction in the use of this product. If the Anti-Fold Bar is not properly installed, personal injury and damage to the Anti-Fold Bar could result.**
- ⚠ **WARNING: If components are damaged or missing, contact your dealer immediately. DO NOT use substitute parts. Use only Everest & Jennings replacement parts. Non-Everest & Jennings replacement parts could cause personal injury and damage to the Anti-Fold Bar.**
- ⚠ **WARNING: Cancer and Reproductive Harm - [www.p65warnings.ca.gov](http://www.p65warnings.ca.gov).**
- ⚠ **WARNING: GF Health Products, Inc. assumes no responsibility for any damage or injury caused by improper assembly or use of this product.**

**INSTALLATION**

*Tools needed: Phillips screwdriver, 7/16" wrench*

**Unpacking**

1. Check for any obvious damage to the carton or its contents. If damage is evident, notify the carrier or your Graham-Field authorized distributor.
2. Remove all loose packing from the carton.
3. Carefully remove all components from the carton.

**Installation (see picture)**

1. Open wheelchair completely.
2. Position Anti-Fold Bar in position of choice, as shown in picture at right, on both sides of wheelchair. Note: The mounting position shown with dotted lines above horizontal tube will not work with models that have fixed-arm sideframes.
3. Install screws as shown through clamps on both sides.
4. Install nuts on screws. Use Phillips screwdriver and 7/16" hex wrench to tighten. Ensure both Anti-Fold Bar clamps are securely installed on sideframe tubes.

- ⚠ **WARNING: Ensure the Anti-Fold Bar is installed as described before use.**

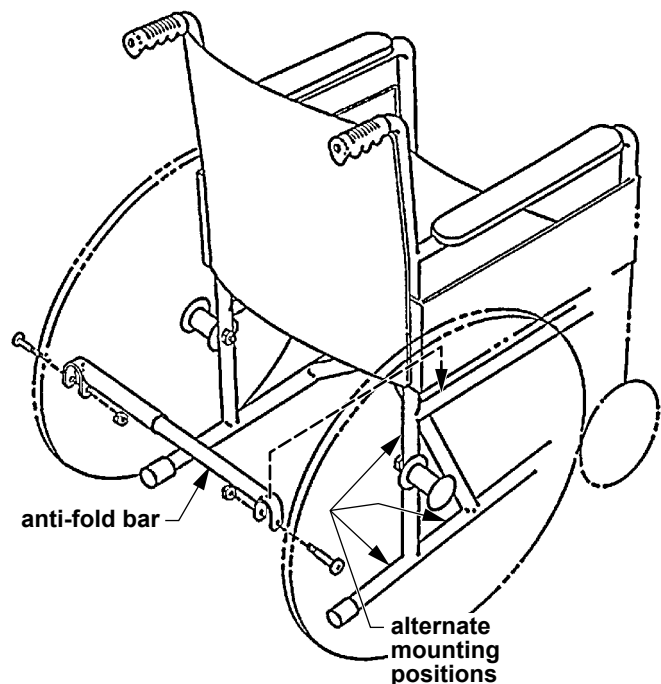

**anti-fold bar installation locations**

## MAINTENANCE / CLEANING

**⚠ WARNING: Check the fit and tightness frequently of all fasteners to ensure the Anti-Fold Bar is securely assembled.**

Regular cleaning is recommended. To clean: gently wipe the Anti-Fold Bar with a soft, clean cloth dampened with water and a mild NONABRASIVE detergent (household cleaner, soapy water, or hospital grade disinfectant), rinse Anti-Fold Bar with a soft, clean cloth dampened with clear water, and dry Anti-Fold Bar with a clean, soft cloth.

**▲ NOTICE: Do not use cleansers that could damage the Anti-Fold Bar's finish.**

## LIMITED WARRANTY

### SCOPE OF WARRANTY

GF Health Products, Inc. ("GF") warrants to the Original Purchaser only that it will replace or repair components, at GF's sole discretion, that are defective in material or workmanship under normal use and service. All warranties are conditioned upon the proper use of the products strictly in accordance with good commercial practice and applicable GF instructions and manuals, including proper use and maintenance. To the extent that a component is warranted by a third party, GF conveys all of its rights under that warranty to the original purchaser, to the extent permitted. Original Purchaser is one who purchases this product new and unused from GF or a GF Distributor. This limited warranty shall only apply to defects that are reported within the applicable warranty period and which, upon examination by GF or its authorized representative, prove to be a warranty item. This limited warranty is not transferable. Within the guidelines set forth in this document, this product is warranted for six (6) months. The applicable warranty period shall commence from date of shipment to the Original Purchaser, unless there is an expiration date on the component in which case the warranty shall expire on the earlier of warranty period or the expiration date.

### OBTAINING WARRANTY SERVICE

This limited warranty shall only apply to defects that are reported to the Distributor from whom the Customer purchased the product within the applicable warranty period. If there is not a Distributor, you must contact GF directly by calling 1.770.368.4700, sending a fax request to 1.770.368.2386, or by e-mailing a request to [cs@grahamfield.com](mailto:cs@grahamfield.com). Specific directions will be provided by the Customer Service Representative. Failure to abide by the specific directions will result in denial of the warranty claim.

### EXCLUSIONS

The warranty does not cover and GF shall not be liable for the following:

- 1) Defects, damage, or other conditions caused, in whole or in part, by misuse, abuse, negligence, alteration, accident, freight damage, tampering or failure to seek and obtain repair or replacement in a timely manner;
- 2) Products which are not installed, used, or properly cleaned and maintained as required in the official manual for the applicable product;
- 3) Products considered to be of a non-durable nature including, but not limited to: casters, filters, fuses, gaskets, lubricants, and charts;
- 4) Accessories or parts not provided by GF;
- 5) Charges by anyone for adjustments, repairs, replacement parts, installation or other work performed upon or in connection with such products which are not expressly authorized in writing, in advance, by GF;
- 6) Any labor or shipping charges incurred in the replacement part installation or repair;
- 7) Costs and expenses of regular maintenance and cleaning; and
- 8) Representations and warranties made by any person or entity other than GF.

### ENTIRE WARRANTY, EXCLUSIVE REMEDY AND CONSEQUENTIAL DAMAGES DISCLAIMER

THIS WARRANTY IS GF'S ONLY WARRANTY AND IS IN LIEU OF ALL OTHER WARRANTIES, EXPRESS OR IMPLIED. GF MAKES NO IMPLIED WARRANTIES OF ANY KIND INCLUDING ANY IMPLIED WARRANTIES OF MERCHANTABILITY OR FITNESS FOR A PARTICULAR PURPOSE.

IF ANY MODEL OR SAMPLE WAS SHOWN TO THE CUSTOMER, SUCH MODEL OR SAMPLE WAS USED MERELY TO ILLUSTRATE THE GENERAL TYPE AND QUALITY OF THE PRODUCT AND NOT TO REPRESENT THAT THE PRODUCT WOULD NECESSARILY CONFORM TO THE MODEL OR SAMPLE IN ALL RESPECTS.

THIS WARRANTY IS LIMITED TO THE REPAIR OR REPLACEMENT OF THE DEFECTIVE PARTS. GF SHALL NOT BE LIABLE FOR AND HEREBY DISCLAIMS ANY DIRECT, SPECIAL, INDIRECT, INCIDENTAL, EXEMPLARY OR CONSEQUENTIAL DAMAGES, INCLUDING, BUT NOT LIMITED TO: DAMAGES FOR LOSS OF PROFITS OR INCOME, LOSS OF USE, DOWNTIME, COVER, OR EMPLOYEE OR INDEPENDENT CONTRACTOR WAGES, PAYMENTS AND BENEFITS.

The warranties contained herein contain all the representations and warranties with respect to the subject matter of this document, and supersede all prior negotiations, agreements and understandings with respect thereto. The recipient of this document hereby acknowledges and represents that it has not relied on any representation, assertion, guarantee, warranty, collateral contract or other assurance, except those set out in this document. Some states do not allow the exclusion of certain remedies; in those instances that state's law will control. This warranty gives you specific legal rights, and you may also have other rights which vary from state to state.

For additional information on this product or this warranty, please contact a GF Customer Service Representative.

### NOTES:

- 1) Additional terms and conditions may apply.
- 2) Freight claims must be notated on the appropriate shipping documents and must be made with immediacy. International, federal and state regulations govern specific requirements for freight claims. Failure to abide by those regulations may result in a denial of the freight claim. GF will assist you in filing the freight claim.
- 3) Claims for any short shipment must be made within three (3) days of the invoice date.



1.770.368.4700

Information contained herein is subject to change.

The most current and complete product information can be found on our website.

[www.grahamfield.com](http://www.grahamfield.com)

Follow us on



© 2006, GF Health Products, Inc. All Rights Reserved.

E&J, Everest & Jennings, and Graham-Field are trademarks of GF Health Products, Inc., One Graham-Field Way, Atlanta GA 30340-3140  
GF Health Products, Inc. is an ISO 13485 Certified Company. • Manufactured for GF Health Products, Inc. • Made in Taiwan